



### ■ Description

The TouchStart™ is an ergonomic alternative to a mechanical palm button switch. These switches are often used to cycle industrial machinery such as punch presses. Unlike mechanical switches, which can require substantial force to operate, the TouchStart requires no actuation force. It detects the operator's hand and actuates its output relays with a mere touch of the button.

The design of the TouchStart includes circuitry to prevent false triggering from the presence of Radio Frequency Interference (RFI).

The TouchStart has been tested by Underwriters Laboratory and is recognized under Standard UL 491, "Standard for Power Operated Machine Controls and Systems." This is the only UL standard dedicated to operator safety in press control applications. The requirements of UL 491 are in accordance with the following Standards:

- NFPA79 The Standard for Metal Working Tools.
- NFPA70 National Electrical Code.
- ANSI B11.1 Standard for the Construction, Care and Use of Mechanical Power Presses.
- OSHA Section 1910.217.

J  
two-hand control

## TouchStart™ Capacitive Palm Button

- No physical pressure required to actuate switch—reduces the likelihood of wrist injury caused by repetitive motion.
- Excellent sensitivity—sensor is designed to operate even if operator is wearing gloves.
- RFI Immunity—special circuitry inhibits output in the presence of RFI that would otherwise cause false triggering of output.
- AC version is UL Recognized—meets the applicable requirements in the proposed first edition of UL 491.
- Saves time and money.
  - Easy mounting in a single hole.
  - Wiring is simplified because terminals are clearly identified and easily accessible.
  - No special power supplies are required because switch is available in either 120 VAC or 24 VDC versions.



Go to the Engineering Guide  
For in-depth information on  
safety standards and use.



### Important Installation Instructions

This sensor has been tested to meet requirements regarding safety devices. Before installing, refer to ANSI B11.1, B11.19, and OSHA 1910.217.

ANSI Standard B11.19-2003 gives the following definitions:

#### 8.4.1.2 Two-Hand Trip Devices

Each two-hand trip device shall be designed and constructed to protect each hand trip control against unintended or inadvertent operation.

The two-hand trip device shall have the individual hand controls arranged by design, construction, or separation to require the use of both hands for actuation.

The two-hand trip device shall be designed and constructed to require concurrent operation of both hand trip controls to initiate the machine cycle.

When used in single cycle mode, the two-hand trip function shall incorporate an antirepeat feature.

#### 8.4.1.3 Two-Hand Control Devices

The two-hand control device shall have individual hand controls arranged by design, construction, or separation to require the use of both hand controls for actuation.

The two-hand control device shall be designed and constructed to protect each hand control against unintended or inadvertent actuation.

The two-hand control device shall require the concurrent actuation of both hand controls within a certain time limit before initiating hazardous motion.

Release of either hand control during the hazardous portion of the machine cycle shall initiate a stop command. Release and

reactivation of both hand controls is required before motion is reinitiated.

Components, subassemblies or modules of the device shall meet the requirements of 6.1.

Rings or shrouds are commonly used to protect palm-actuated buttons from unintentional actuation.

Precautions in design or installation are needed to prevent actuation of two buttons by the use of one hand and the elbow of the same arm and to inhibit other circumvention of the two-hand requirement.

The device shall be located at a distance from the nearest hazard such that the operator cannot reach the hazard with a hand or other body part before cessation of motion of the hazardous portion of the machine cycle. Descriptions of formulas for distances between the switches and from nearest hazard can be found in American National Standards Institute (ANSI) B11.1 and B11.19-2003.

Since each two-hand control or trip application is different the user needs to make sure that all Occupational Safety and Health Administration (OSHA) and American National Standards



TouchStart palm button assembly with Round Ring Guard, model TS-R and TS-B1



TouchStart palm button assembly with Square Ring Guard, model TS-SQ and TS-B1.

Institute (ANSI) requirements are followed.

This device shall be installed such that the distance between the terminal connections of the

palm button switch with leads installed and a dead metal part (including the enclosure) is a minimum of 1/4 inch.

■ **Application**

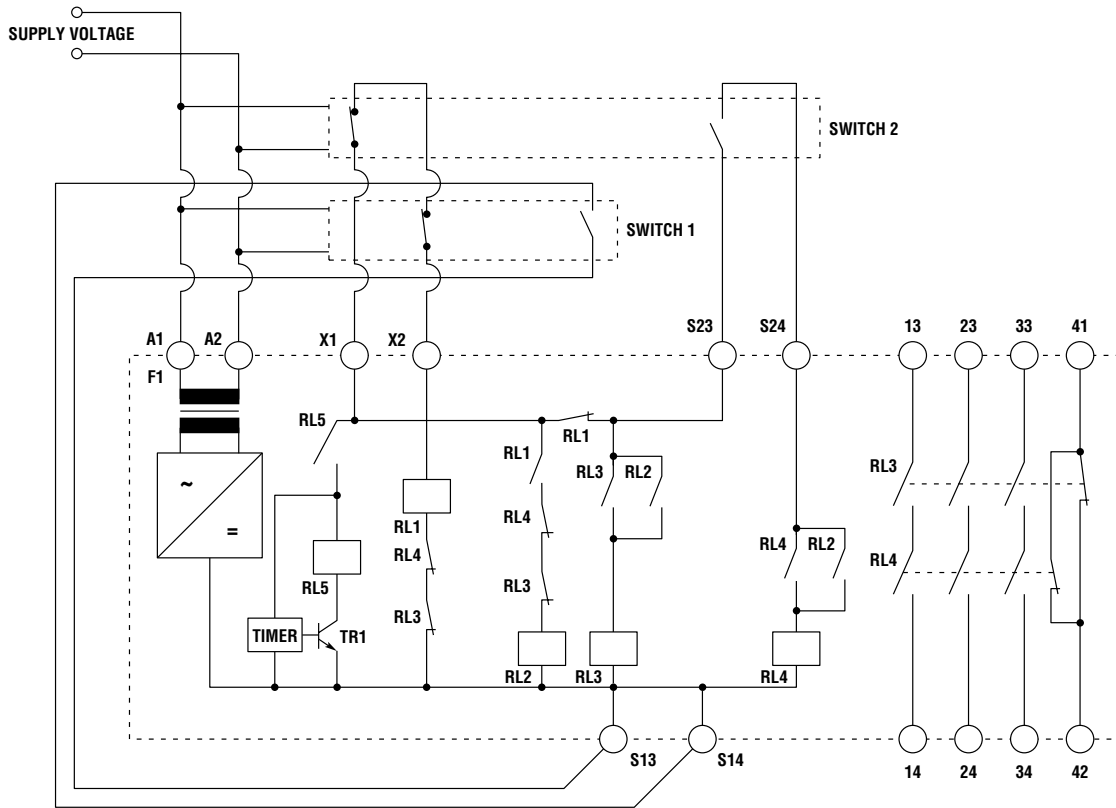

two-hand control

■ **Wiring**

**Connection Diagram**

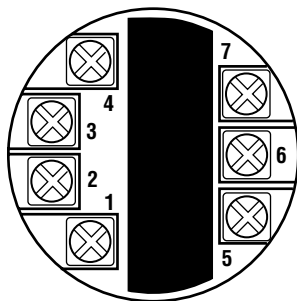

**TS-10**

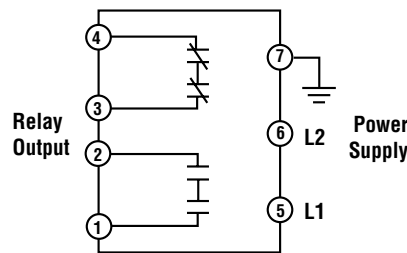

**TS-20**

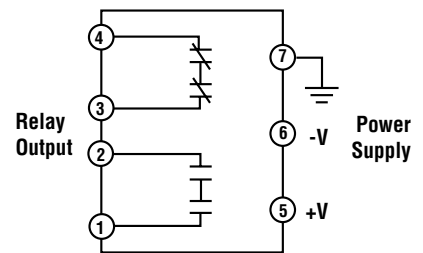

**A** Go to the Engineering Guide  
For in-depth information on safety standards and use.

■ Dimensions—in./mm

**TouchStart**

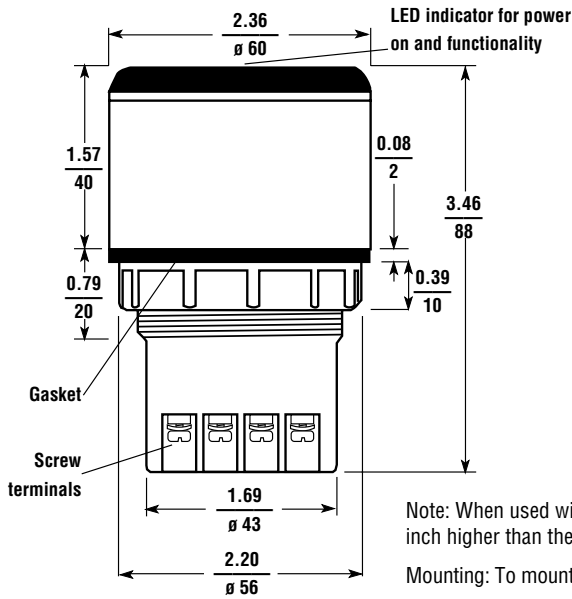

**Square Ring Guard TS-SQ**

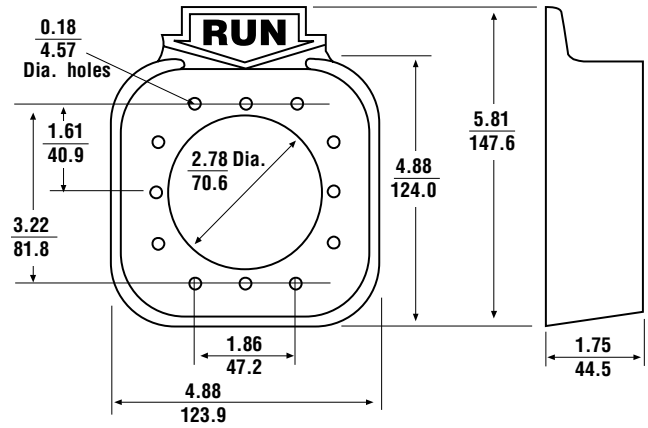

Note: When used with a shroud or ring, the top of the shroud or ring must be at least 1/2 inch higher than the top surface of the TouchStart.

Mounting: To mount the TouchStart, cut a mounting hole of 1-7/8 in diameter (47.6 mm).

**Round Ring Guard TS-R**

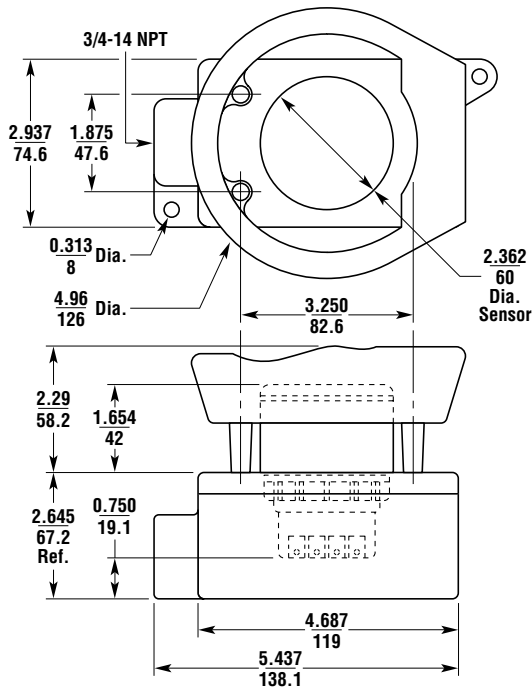

**TS-B1 and TS-B2 Side View**

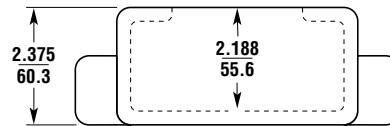

**TS-B1**

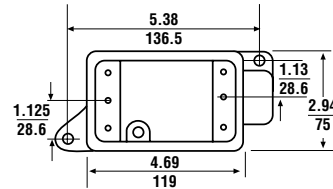

**TS-B2**

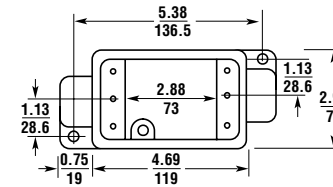

## ■ Specifications

TS-10 for 120 VAC; TS-20 for 24 VDC	
<b>Max Wiring Size:</b>	14 AWG (1)
<b>Housing Material:</b>	Nory IN190
<b>Weight:</b>	313 g (11 oz.)
<b>Actuation:</b>	Hand sensitive requiring no pressure to initiate, operates with or without gloves
<b>Power Supply</b>	
<b>TS-10:</b>	120 VAC ±10%, 45 to 60 Hz
<b>TS-20:</b>	24 VDC ±10%
<b>Power Consumption:</b>	≤1 W
<b>Indicator:</b>	Red LED, illuminates when relays are energized
<b>Output:</b>	Two relays provide 1 set of normally open contacts, 1 set of normally closed contacts. Force-guided contacts are used.
<b>Contact Ratings:</b>	1 A at 250 VAC max resistive; 1 A @ 90 VDC max resistive
<b>Mechanical Life:</b>	Greater than 50 million operations
<b>Electrical Life:</b>	Greater than 5 million operations at loads less than 50 VA
<b>Mechanical Shock:</b>	45 g for 2 ms
<b>Vibration:</b>	4 g at f ≤60 Hz and amplitude ≤ 1 mm
<b>Relative Humidity:</b>	≤ 99%
<b>Noise Protection:</b>	Bursts to 2 kV, spikes of 500V, electrostatic fields to 8 kV*
<b>Weldfield Immunity:</b>	Resistor welding up to 50 kA AC/DC (in suitable enclosure)*
<b>RFI:</b>	≤ 8 V/m
<b>Protection:</b>	IP64
<b>Temperature Range:</b>	-18 to 50°C (0 to 122°F)
<b>Max Response Times:</b>	On = 60 ms; Off = 80 ms
<b>Approvals:</b>	CE marked for all applicable directives, UL and C-UL

Specifications are subject to change without notice.

\* If any of these values are exceeded, the TouchStart will default to a safe state (output relays de-energized). The TouchStart automatically resets when conditions fall below the limit.

## ■ Ordering

Model	Description
TS-10	TouchStart Palm Button, includes mounting jam nut and gasket, 120 VAC
TS-20	TouchStart Palm Button, includes mounting jam nut and gasket, 24 VDC
TS-SQ	Plastic, square ring guard, mounting screws, spacers
TS-R	Metal, round ring guard, mounting screws, spacers
TS-B1	Electrical box, with one conduit hub (3/4 in.), cover plate for box, gasket for box
TS-B2	Electrical box, with two conduit hubs (3/4 in.), cover plate for box, gasket for box

To order a complete TouchStart Palm button, two-hand control system, order one of each of the following:

TS-10 or TS-20	TouchStart Palm Button—order two each
TS-SQ or TS-R	Ring Guards or other shields must be installed to avoid accidental operation in safety applications per OSHA and ANSI — order two each
TS-B1 or TS-B2	Electrical box—order a total of two (one of each type or two of one type)
SR104P	Anti-tie down relay — order one per system

### Warning!

This product may cause substantial personal injury or property damage if it is not installed and used in accordance with the manufacturer's instructions and in accordance with regulations of the Occupational Safety and Health Administration Part 1910.217, the procedures prescribed by the American National Standards Institute B11.1 and B11.19, and all other applicable regulations, procedures and codes. The manufacturer shall not be responsible nor liable for any injury or damage resulting from use of the product in any such applications or the failure to comply with any such regulation, procedure or code.